



ELECTRIC PALLET STACKER MM10 | MM10i | ML10

CAPACITY 1000 KG | SERIES 1167-02

Safety

The guards of the off-centred tiller head effectively shield the operator's hands and keep him safely within the truck's contours with excellent visibility through the mast. The long, low mounted tiller arm places the operator at a safe yet comfortable working distance. The MM10 and ML10 also feature an effective parking brake to hold the truck safely on slopes.

Performance

The MM10 is an ideal stacker for light duty applications such as order picking and pallet handling. This monomast stacker also includes an initial lift version for additional versatility particularly on gradients. The ML10 is perfect for use as a work bench in manufacturing or maintenance applications. Thanks to the wide choice of mast lift heights the ML10 offers a highly cost-effective and productive solution for many applications combined with occasional stacking of loads up to 1000 kg.

Comfort

When used as a work bench, the ML10 eliminates any back strain as components or raw materials do not need to be lifted off the ground and

the forks can be raised to a comfortable working height. The dual butterfly controls on the ergonomic tiller head ensure precise traction and lift operation with either hand. A built-in charger enables opportunity charging at any convenient power point for optimum uptime.

Reliability

The durable drive unit of the MM10 and ML10 delivers consistent high performance and reliability. The robust chassis has a reinforced fork structure for safe, efficient handling of loads up to 1000 kg. There is a battery discharge indicator with an automatic cut-off when the battery needs to be charged and an emergency isolator button for safety.

Service

The DC drive motor optimizes uptime between routine service periods and reduces service costs, while a reliable, energy efficient controller delivers smooth handling performance. Fast, easy access to all internal components ensures service tasks are completed with a minimum of delay.

TECHNICAL DATA

ACCORDING TO VDI 2198

Characteristics	1.1	Manufacturer		LINDE	LINDE	LINDE
	1.2	Model designation		MM10	MM10i	ML10
	1.3	Power unit: Battery, diesel, gasoline, LPG		Electric	Electric	Electric
	1.4	Operation		Pedestrian	Pedestrian	Pedestrian
	1.5	Load capacity	Q [t]	1.0	1.0	1.0
	1.6	Load center	c [mm]	600	600	600
	1.8	Axle center to fork face	x [mm]	805	805	795
	1.9	Wheelbase	y [mm]	1126	1260	1240
	Weight	2.1	Service weight	[kg]	462	520
2.2		Axle load with load, front/rear	[kg]	530/950	580/1140	596/1002
2.3		Axle load without load, front/rear	[kg]	350/120	350/170	446/152
Wheels and types	3.1	Tyre: SE=(superelastic), P=(pneumatic)		PU/PU	PU/PU	PU/PU
	3.2	Tyre size, front		210x70	210x70	210x70
	3.3	Tyre size, rear		80x60	80x60	80x60
	3.5	Wheels, number front/rear (X=drive)		1x+1/4	1x+1/4	1x+1/4
Dimensions	4.2	Height of mast, lowered	h_1 [mm]	1940	1940	2097
	4.3	Free lifting	h_2 [mm]	1505	1480	150
	4.4	Lift	h_3 [mm]	1517	1513	2927
	4.5	Height of mast, extended	h_4 [mm]	1955	2090	3487
	4.6	Initial lift	h_5 [mm]	n/a	115	n/a
	4.9	Height of tiller arm in driving position, min/max	h_{t_4} [mm]	800/1250	800/1250	800/1250
	4.15	Fork height, lowered	h_{15} [mm]	88	88	88
	4.19	Overall length	l_1 [mm]	1615	1750	1740
	4.20	Length to fork face	l_2 [mm]	465	600	590
	4.21	Overall width	b_1/b_2 [mm]	800	796	800
	4.22	Fork dimensions $s \times e \times l$	$s_e \times l$ [mm]	60x170x1150	60x190x1150	55x160x1150
	4.24	Width of fork carriage	b_3 [mm]	680	680	600
	4.25	Distance between fork-arms	b_5 [mm]	550	560	560
	4.32	Ground clearance with load, center of wheelbase	m_2 [mm]	28	26	30
	4.34	Aisle width, 800 x 1200 along forks	A_{31} [mm]	2100	2260	2219
4.35	Turning radius	W_3 [mm]	1337	1500	1450	
Performance	5.1	Travelling speed, with/without load	[km/h]	4/4.5	4/4.5	4.5/4.8
	5.2	Lifting speed, with/without load	[m/s]	0.10/0.17	0.10/0.14	0.12/0.22
	5.3	Lowering speed, with/without load	[m/s]	0.2/0.13	0.2/0.13	0.2/0.13
	5.8	Max. gradeability, laden/unladen	%	5/15	5/15	5/15
	5.9	Acceleration time with/without load	[s]	n/a	n/a	n/a
	5.10	Service brake		Electromagnetic	Electromagnetic	Electromagnetic
Drive Unit	6.1	Drive motor rating S2 60 min	[kW]	0.65	0.65	0.65
	6.2	Lift motor rating at S3 10%	[kW]	2.2	2.2	2.2
	6.3	Battery acc. to DIN 43531/35/36 A, B, C, no		n/a	n/a	n/a
	6.4	Battery voltage, nominal capacity K5	[V/Ah]	2x12/85	2x12/85	2x12/125
	6.5	Battery weight	kg	2x25	2x25	2x33
	6.6	Energy consumption acc. to VDI cycle	[kW/h]	n/a	n/a	n/a
Other	8.1	Type of drive control		DC	DC	DC
	8.4	Noise level	[dB (A)]	74	74	74

MM10

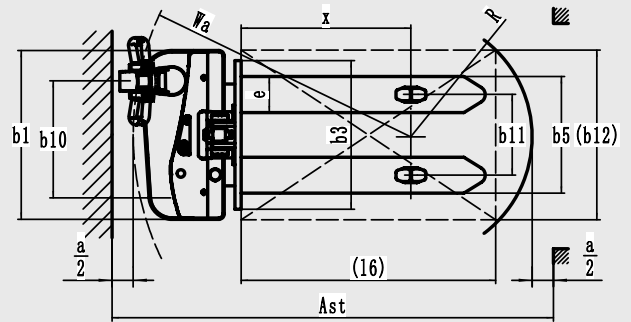
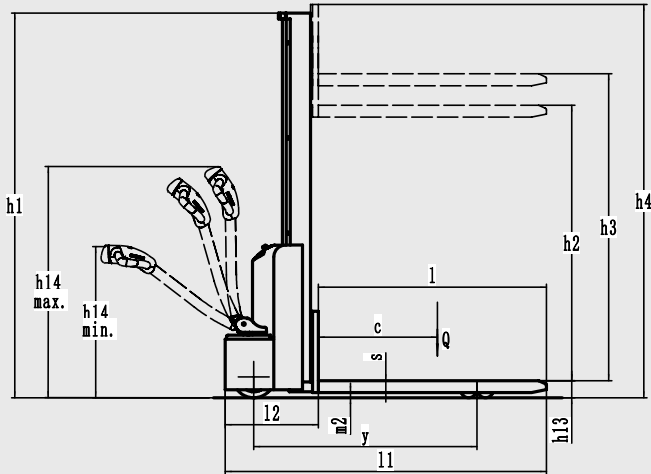

MM10i

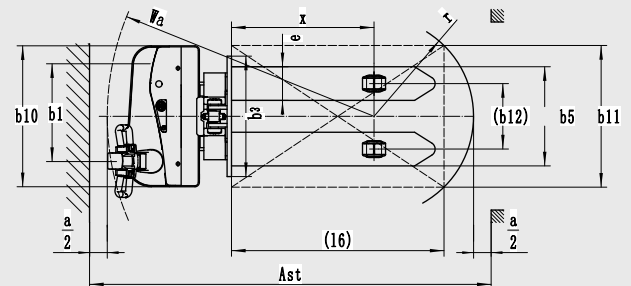
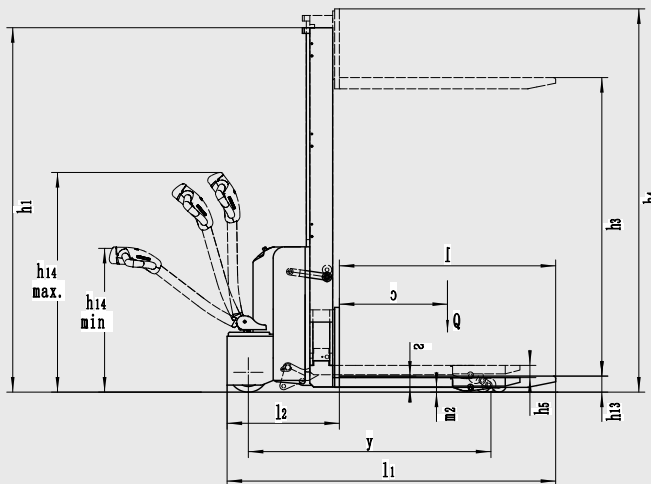

ML10

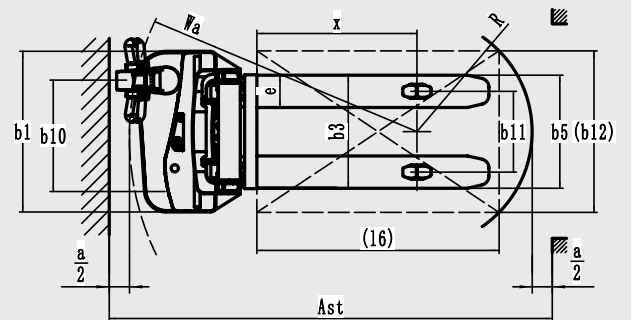
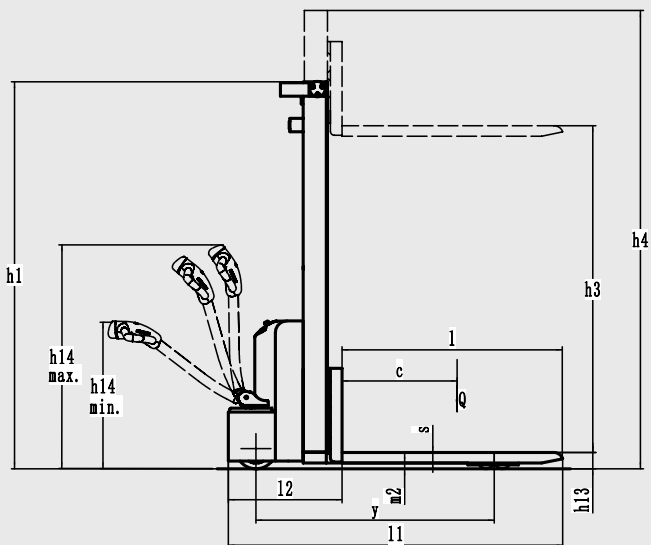

STANDARD EQUIPMENT / OPTIONAL EQUIPMENT

STANDARD EQUIPMENT

Mechanical steering

4,5 km/h travel speed

DC maintenance-free drive motor

Display with hourmeter

Key switch

Electromagnetic brake

Automatic parking brake

Drive wheel polyurethane

Tandem polyurethane load wheels

Fork: 1150 x 560 mm (MM10i, ML10) 1150 x 550 mm (MM10)

Battery: 24 V / 85 Ah (MM10, MM10i) 24 V / 125 Ah (ML10)

Belly switch on tiller head

OPTIONAL EQUIPMENT

Drive wheel: wet grip

Various mast lift heights

Creep speed

Charger interlock (compulsory for UK)

Plug: UK type

MAST TABLES

Mast MM10 (in mm)		1517 M	1867 M
Lift	h_3	1517	1867
Lift+fork height	h_3+h_{13}	1605	1955
Height,mast lowered	h_1	1940	2290
Closed height (with free lift at 150 mm)	$h_1 \#$	1940	2290
Height,mast extended	h_4	1955	2305
Free lift	h_2	1505	1855

Mast MM10i (in mm)		1513 M	1863 M
Lift	h_3	1513	1863
Lift+fork height	h_3+h_{13}	1608	1958
Height,mast lowered	h_1	1940	2290
Closed height (with free lift at 150 mm)	$h_1 \#$	1940	2290
Height,mast extended	h_4	2011	2361
Free lift	h_2	1480	1830

Mast ML10 (in mm)		2427 S	2627 S	2927 S	3227 S
Lift	h_3	2427	2627	2927	3227
Lift+fork height	h_3+h_{13}	2515	2715	3015	3315
Height,mast lowered	h_1	1772	1872	2022	2172
Closed height (with free lift at 150 mm)	$h_1 \#$	1847	1947	2097	2247
Height,mast extended	h_4	2987	3187	3487	3787
Free lift	h_2	150	150	150	150

Other masts on request

M = Mono, S = Standard

For MM10i, it will show a different closed height data if you use initial lift function.

FEATURES

Drive unit

- 0.65 kW DC drive motor
- Adjustable parameters: travel speed up to 4.5 km/h, acceleration
- Creep speed (option)

Energy

- Built in AGM battery
- MM10, MM10i 80 Ah and ML10 125 Ah
- Up to 3 h autonomy



Braking system

- Highly efficient electromagnetic brake applied by moving the tiller to fully up or down position
- Automatic braking on releasing traction butterfly or reversing direction
- Truck slows before coming to a stop, remaining under total control at all times
- Proofed emergency button

Chassis

- Robust metal cover protects drive system and components
- Low chassis skirt protects operator's feet
- Long, low mounted tiller ensures operator is safe yet comfortable distance from the truck
- Rugged, reinforced fork structure provides safe handling of loads up to 1000 kg



Controls

- Traction and lift controls grouped on ergonomic tiller head
- Dual butterfly control levers for use with either hand
- Belly switch on tiller head stops truck when actuated

Operator compartment

- Reliable and precise battery discharge indicator
- Operating hour meter
- Built-in charger enables opportunity charging at any convenient power point
- Key switch

Service

- Main components are easily accessible by simply removing the motor service panel
- General arrangement of the technical components has been thought to be positioned to reduce wires at their minimum

Subject to modification in the interest of progress. Illustrations and technical details could include options and not binding for actual constructions. All dimensions subject to usual tolerances.

Presented by:

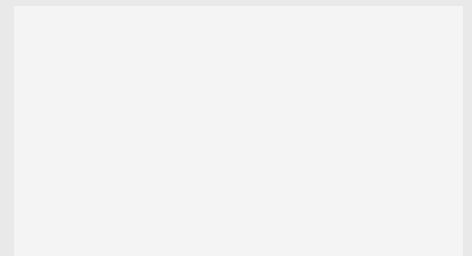

Linde Material Handling GmbH
Postbox 10 0136 | 63701 Aschaffenburg | Germany
Phone + 49 6021 99 0 | Fax + 49 6021 99 15 70
www.linde-mh.com | info@linde-mh.com

Printed in Germany 767.e.1.1217.lndA.Ki