



Urban Electric Pallet Truck Capacity 500 kg CiTi One

SERIES 1130

Safety

Thanks to its traction and lift motors, the CiTi Truck eliminates the physical effort which causes physical stress and strain to users. It is equipped with an effective parking brake to hold the truck safely on slopes or on lorry tail lifts. The proportional joystick control allows the truck to be manoeuvred with precision.

Performance

The CiTi Truck offers a unique solution to the market. Thanks to the unique curved shape of the load wheel bogies which articulate over obstacles, and the traction motor incorporated in the drive wheel which provides the power, the CiTi Truck can cross pedestrianised and vehicle access areas, cope with pavements and curbs up to 70mm high, and handle ramps.

Comfort

Simplicity and ergonomics are the key concepts behind this truck. A joystick controls traction and lift and is accessible by either hand. The use of rubber drive and load wheels ensures impressively quiet operation on tail lifts, pedestrian zones, or over paved floors. Its compactness guarantees easy and precise manoeuvring even in the tightest spaces.

Reliability

CiTi Truck is equipped with a new generation of battery: Ni/ Cd and Ni/Mh. Intelligent and compact, it accepts top-up recharging at any time of the day. In order to achieve an optimal quality and reliability, the conception and fabrication of the truck are completely managed by Linde.

Service

This truck has been designed to minimize and simplify maintenance. The specially developed solid drive tyre, the absence of a hydraulic lift system, and the brushless DC motor are some examples of the technologies chosen for this truck. The CiTi Truck also offers the environmental benefit of 95% recyclability.



Features

Coping with different surfaces

- Large diameter drive wheel
- Load wheels mounted in a unique curved bogie which rolls over obstacles
- Copes with pavements and curbs up to 70 mm high
- Able to operate effectively over irregular surfaces

Multifunction display

- Reliable and precise battery discharge indicator
- Hour-meter
- Operational status display



Controls

- Traction and lift control via easyControl (joystick)
- Simple operation using the thumb
- Integrated horn
- Belly switch on the tiller head stops the truck



Low noise level

- Solid rubber tyre absorbs shocks
- Silent rubber load wheels
- Exceptionally quiet motor
- Piek certified in its standard configuration (traction + lifting)



Traction system

- Traction motor inside the drive wheel
- Smooth traction speed controller
- Progressive acceleration and deceleration
- Booster effect for handling obstacles



Braking

- Automatic deceleration when the joystick is released
- Automatic parking brake when the tiller arm is released
- Key switch to immobilise the truck

Energy

- Compact and interchangeable batteries
- Sealed Ni/Cd or Ni/Mh technology
- 5/9/15 Ah capacity, for up to 2 hours battery life
- 110 / 220 V external charger



CAN-Bus communication

- Electronic diagnosis of truck functions during ignition
- Easy and quick access to components
- Sealed and maintenance-free traction motor

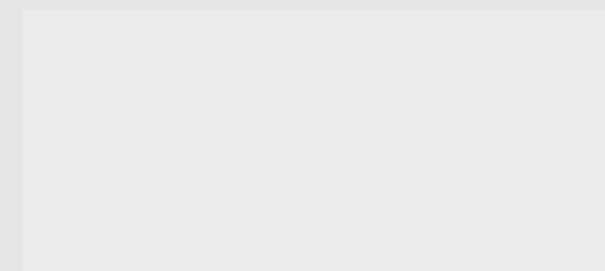

Linde Material Handling GmbH, Postfach 10 01 36, 63701 Aschaffenburg, Germany,
Phone +49.6021.99-0, Fax +49.6021.99-1570, www.linde-mh.com, info@linde-mh.com



Subject to modification in the interests of progress. Illustrations and technical details not binding for actual constructions. All dimensions subject to usual tolerances.

Printed in Germany 071.e.3.0411.indC.KI

Technical Data according to VDI 2198

Characteristics	1.1	Manufacturer		LINDE
	1.2	Model designation		Citi one
	1.3	Power unit		Battery
	1.4	Operation		Pedestrian
	1.5	Load capacity	Q (t)	0.5
	1.6	Load centre	c (mm)	600
	1.8	Axle centre to fork face	x (mm)	906 / 972 ¹⁾
	1.9	Wheelbase	y (mm)	1119 / 1185 ^{1,2)}
	Weights	2.1	Service weight	(kg)
2.2		Axle load with load, front/rear	(kg)	208 / 390 ³⁾
2.3		Axle load without load, front/rear	(kg)	71 / 27
Wheels/Tyres	3.1	Tyres rubber, SE, pneumatic, polyurethane		Rubber
	3.2	Tyre size, front		Ø 310 x 85
	3.3	Tyre size, rear		Ø 80 x 37
	3.5	Wheels, number front/rear (x = driven)		1x / 2
	3.6	Track width, front	b10 (mm)	0
	3.7	Track width, rear	b11 (mm)	410 ⁴⁾
	Dimensions	4.4	Lift	h3 (mm)
4.9		Height of tiller arm in operating position, min/max	h14 (mm)	650 / 1170
4.15		fork height, lowered	h13 (mm)	85
4.19		Overall length	l1 (mm)	1560
4.20		Length to fork face	l2 (mm)	410
4.21		Overall width	b1/b2 (mm)	550 ⁴⁾
4.22		Fork dimensions	s/e/l (mm)	55 x 100 x 1150
4.25		Fork spread, min/max	b5 (mm)	550
4.32		Ground clearance, centre of wheelbase	m2 (mm)	30 / 155
4.33		Aisle width with pallet 1000 x 1200 across forks	Ast (mm)	1615 ⁵⁾⁶⁾
4.34		Aisle width with pallet 800 x 1200 along forks	Ast (mm)	1815 ⁵⁾⁶⁾
4.35	Turning radius	Wa (mm)	1321 / 1387 ¹⁾⁵⁾	
Performance	5.1	Travel speed, with/without load	(km/h)	4.5 / 6
	5.2	Lifting speed, with/without load	(m/s)	0.037 / 0.054 ³⁾
	5.3	Lowering speed, with/without load	(m/s)	0.049 / 0.058 ³⁾
	5.8	Maximum climbing ability, with/without load	(%)	8.0 / 8.0
	5.9	Acceleration time, with/without load	(s)	7.0 / 6.0
	5.10	Service brake		Electro-magnetic
Drive	6.1	Drive motor, 60 minute rating	(kW)	0.3
	6.2	Lift motor rating at S3 15%	(kW)	0.4
	6.3	Battery according to DIN 43531/35/36 A,B,C,no		Ni cd
	6.4	Battery voltage/rated capacity (5h)	(V/Ah)	36 / 5
	6.5	Battery weight (± 5%)	(kg)	6
	6.6	Power consumption according to VDI cycle	(kWh/h)	0,06
Others	8.1	Type of drive control		Digital
	8.4	Noise level at operator's ear	(dB(A))	< 60.0

1) Forks upraised / lowered
 2) (± 5 mm)
 3) (± 10%)
 4) (± 5 mm)
 5) Tiller in vertical position
 6) Including a 200 mm (min.) operating aisle clearance.

Standard Equipment/Optional Equipment

Standard Equipment

- Traction motor inside the drive wheel
- Lift motor
- Load wheels specifically adapted for city centre application
- Forks: 1150mm long by 550mm width across
- Linde electronic controller
- Automatic parking brake
- Truck immobilised when switched off
- Multifunction display
- Multifunction key: battery bolt, emergency stop and key switch
- Ergonomic operation with joystick control of functions
- Horn
- Safety switch on tiller head
- Low temperature protection down to -15°C
- Tool kit: tools for releasing the parking brake and lifting the forks
- Ni/Cd 5Ah battery
- 110/220 V external slow charger – 1A for 1 battery
- Piek certified in its standard configuration (traction and lifting tests)

Optional Equipment

- Ni/Mh battery, 9 and 15 Ah capacities, for up to 2 hours autonomy
- 110/220 V external - quick charger – 3A for 2 batteries
- Additional 110/220 V external slow charger – 1A for 1 battery

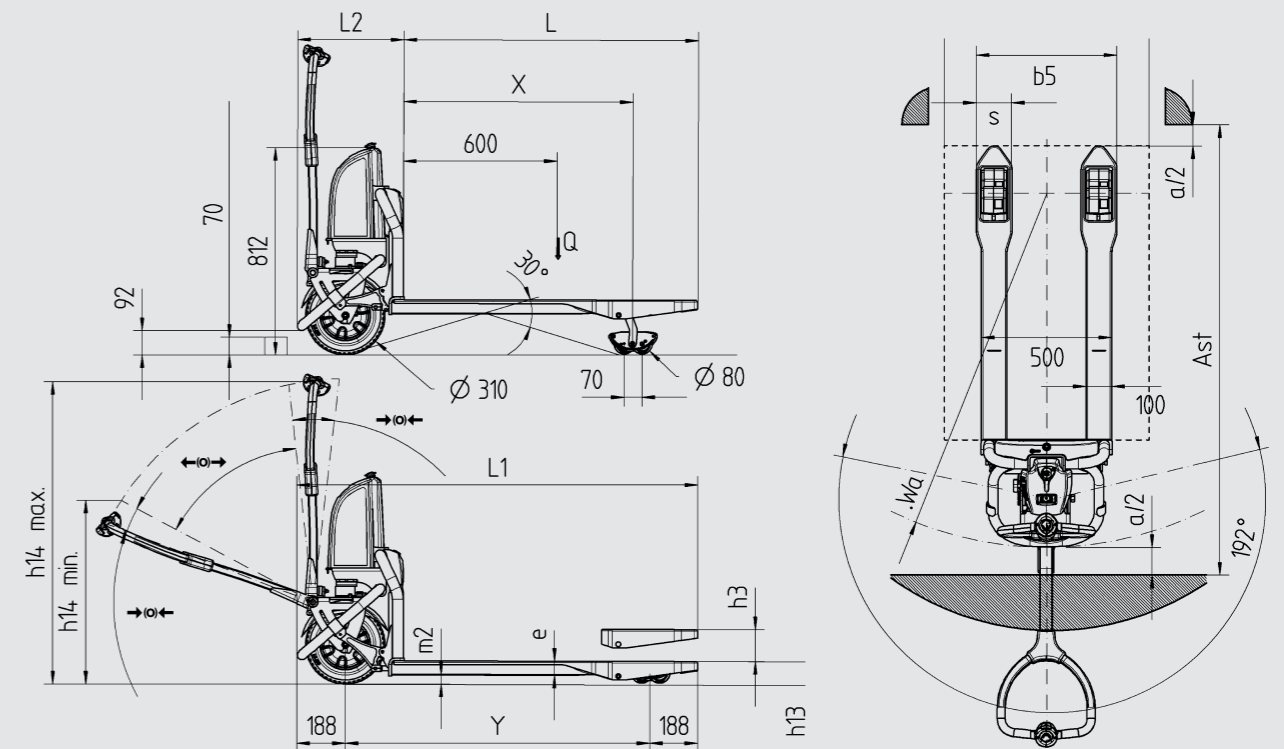

Batteries		Maximum charging time		Maximum recommended crossing ability					
Capacity	Voltage	Technology	Weight	Working time	Slow charger	Quick charger	Load	Step height	Speed in km/h
5 Ah	36 V	Ni / Cd	6,4 kg	Up to 45 min	5 h	1 h 40	150 kg	70 mm	< 2 km/h
9 Ah	36 V	Ni / Mh	7 kg	Up to 75 min	9 h	3 h	300 kg	50 mm	< 2 km/h
15 Ah	36 V	Ni / Mh	10,5 kg	Up to 120 min	15 h	5 h	500 kg	45 mm	< 2 km/h