



Linde Material Handling

Linde



Electric Pallet Truck

MT15 C

Capacity 1.5 t | Series 1131-02

Compact transporter

- 0.75 kW electric drive accelerates and facilitates load transport up to 1.5 tons and increases handling performance in the warehouse
- Compact design ensures best maneuverability in confined spaces
- Easy maneuverability and electric drive relieve employees of physically demanding transport tasks

TECHNICAL DATA (According to VDI 2198)

Characteristics	1.1	Manufacturer		Linde
	1.2	Model		MT15 C
	1.2.a	Series		1131-02
	1.3	Operation		Battery
	1.4	Operator type		Pedestrian
	1.5	Load capacity	Q (t)	1.5
	1.6	Load centre distance	c (mm)	600
	1.8	Load distance	x (mm)	950 (880)
	1.9	Wheelbase	y (mm)	1190 (1120)
Weights	2.1	Service weight	(kg)	115
	2.2	Axle load with load, front/rear	(kg)	540/1075
	2.3	Axle load without load, front/rear	(kg)	100/15
Wheels/Tyres	3.1	Tyres rubber, SE, pneumatic, polyurethane		PU
	3.2	Tyre size, front	(mm)	Φ 210 × 70
	3.3	Tyre size, rear	(mm)	Φ 80 × 60 (Φ 74 × 88)
	3.5	Wheels, number front/rear (x = driven)	(mm)	1x/4 (1x/2)
	3.7	Track width, rear	b11 (mm)	410 (535)
Dimensions	4.4	Lift height	h3 (mm)	115
	4.9	Height drawbar in driving position min./max.	h14 (mm)	750/1190
	4.15	Lowered height	h13 (mm)	80
	4.19	Overall length	l1 (mm)	1550
	4.20	Length to face of forks	l2 (mm)	400
	4.21	Overall width	b1/b2 (mm)	560 (685)
	4.22	Fork dimensions	s/e/l (mm)	50 × 150 × 1150
	4.25	Distance between fork-arms	b5 (mm)	560 (685)
	4.32	Ground clearance, center of wheelbase	m2 (mm)	30
	4.34	Aisle width for pallets 800 × 1200 lengthways	Ast (mm)	2062
4.35	Turning radius	Wa (mm)	1390	
Performance	5.1	Travel speed, laden/unladen	(km/h)	4/4.5
	5.2	Lifting speed, laden/unladen	(m/s)	0.017/0.024
	5.3	Lowering speed, laden/unladen	(m/s)	0.09/0.06
	5.8	Max. gradeability, laden/unladen	(%)	6/16
	5.10	Service brake type		Electric
Drive	6.1	Drive motor rating S2 60 min	(kW)	0.75
	6.2	Lift motor rating at S3 15 %	(kW)	0.5
	6.3	The maximum allowed size battery	(mm)	230 × 260 × 85
	6.4	Battery voltage/nominal capacity K5	(V/Ah)	24/20
	6.5	Battery weight	(kg)	5
	6.6	Energy consumption acc. to VDI cycle	(kWh/h)	0.274
Others	8.1	Type of drive unit		DC
	10.5	Steering type		Mechanical
	10.7	Sound pressure level LpAZ (at the driver's seat)	(dB(A))	< 74

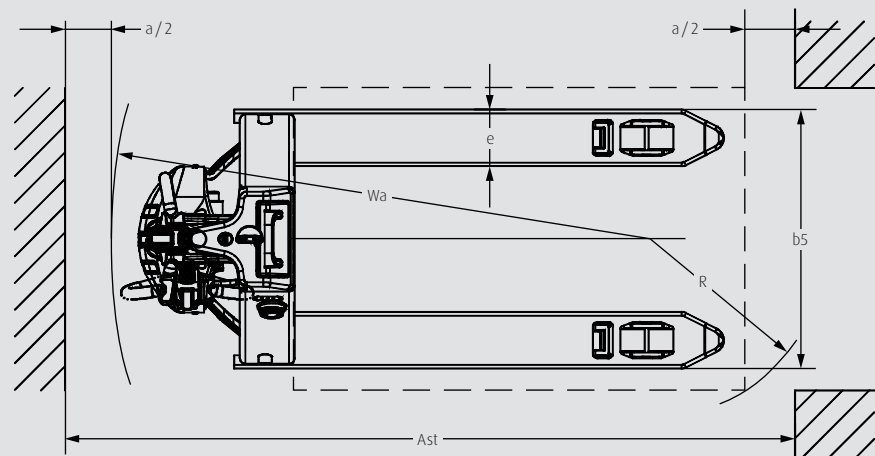
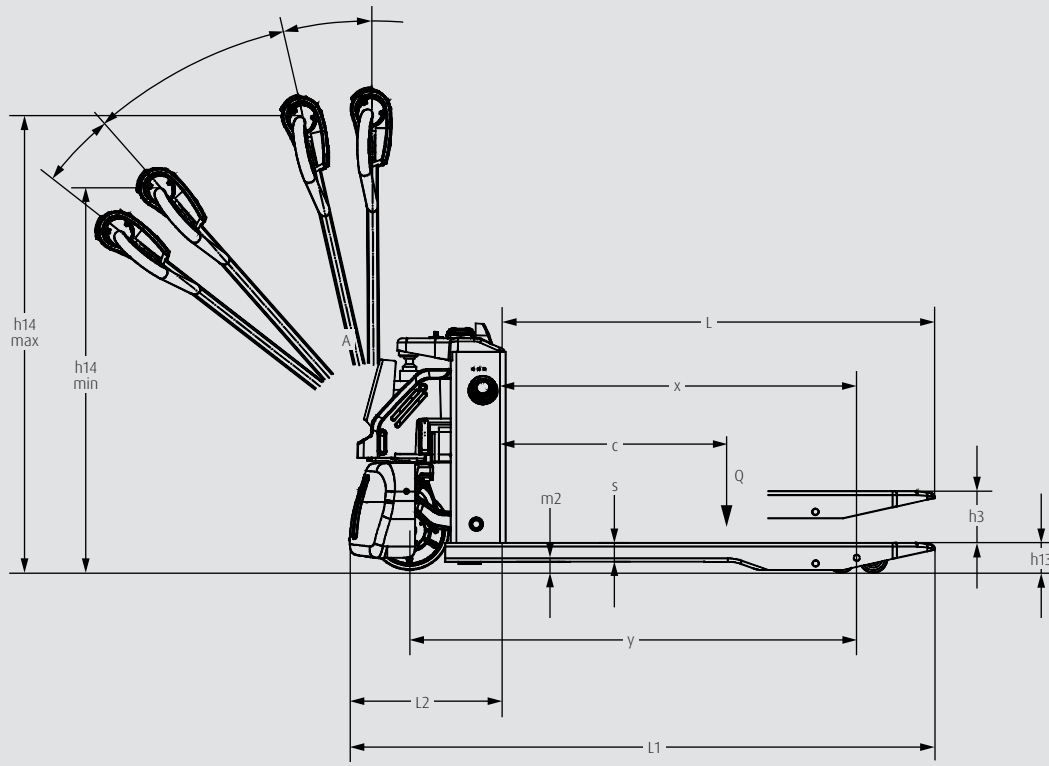



STANDARD AND OPTIONAL EQUIPMENT

Model/Equipment		MT15 C
Safety	Automatic parking break	●
	Horn	●
	Safety switch on tiller head	●
	Robust metal cover	●
	Long and low mounted tiller	●
	Key switch	●
Operation / Load Handling	Creep speed	●
Work-place	Traction and lifted control from ergonomic tiller	●
	LED lights with battery indicator status	●
Attachement / Forks	Fork width 560 mm	●
	Fork width 685 mm	○
Axles and Tyres	Drive wheels polyurethane	●
	Tandem load wheels polyurethane	●
	Single load wheels polyurethane	○
	Double castor wheels	○
Drive and Brake-system	0.75 kW DC motor (maintenance free)	●
	Electromagnetic braking system	●
	Battery 24 V / 20 Ah	●
	Extra Li-ION battery (20 Ah)	○
	External Li-ION 10 A Charger	●

● Standard equipment

○ Optional equipment

CHARACTERISTICS



Long tiller mounted on low chassis

Safety

- Safety distance due to long drawbar protects against accidents
- Low chassis prevents injuries to the feet
- Automatic electromagnetic brake and belly switch reduce risk of accidents
- Efficient parking brake prevents the pallet truck from rolling away on loading ramps or slopes

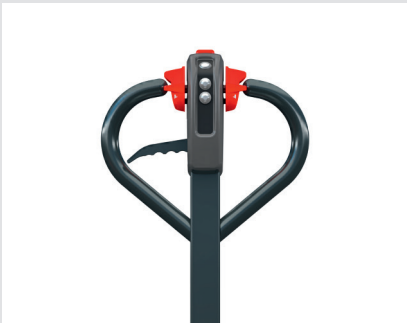

All controls ergonomically integrated in the Linde tiller head

Ergonomics

- Compact chassis and small turning circle ensure best maneuverability in confined spaces
- Creep speed with vertical tiller arm enables precise, smooth steering
- Ergonomically shaped tiller head facilitates operation with both hands using the dual butterfly lever
- The Curtis control enables sensitive load handling and individual adjustment of speed and acceleration



Optimal visibility of the forks and load at all time

Handling

- Effortless load handling over gradients up to 6 percent thanks to electric drive
- The reinforced forks carry up to 1.5 tons load
- Fast transport over short distances with maximum speed of 4.5 km/h
- Stepless lowering of the forks enables precise lowering of the load



Easy plug and play Li-ION battery

Service

- The robust DC motor enables long maintenance intervals and reduces operating costs
- The maintenance and emission-free lithium-ion battery system enables non-stop operation for up to 1.7 hours
- Short charging cycle and opportunity charging provide long operating times
- Easy battery replacement via plug-and-play

Subject to modification in the interest of progress. Illustrations and technical details could include options and not binding for actual constructions. All dimensions subject to usual tolerances.

Presented by:

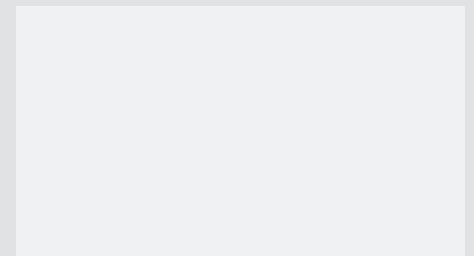

Linde Material Handling GmbH
Carl-von-Linde-Platz | 63743 Aschaffenburg | Germany
Phone + 49 6021 99 0 | Fax + 49 6021 99 1570
www.linde-mh.com | info@linde-mh.com

Printed in Germany | DS_MT15 C_1131-02_en_C_0122